



WARDCRAFT

HINGED STEEL BELTS

for Longer
Jam-Resistant
Service

HINGED STEEL BELTS FOR HEAVY DUTY APPLICATIONS...

...AND LESS DOWNTIME

Unique features of Wardcraft's heavy duty hinged steel belts permit continuous conveyor operation under demanding conditions and minimize downtime when belt repairs may be required.

Wardcraft steel belts withstand heat, shock and abusive environments, and run in coolant/water/oil agents. Applications include the conveying of stampings, forgings, and scrap metal, and the removal of all types of chips (cast iron, steel, aluminum, copper, brass, bronze...). These belts are also used in quench conveyors.

INTERLOCKING SIDE WINGS

The belt's overlapping and interlocking side wings form an integral surface that gives added strength to the belt assembly. The overlapping wings, made of special heavy gauge steel, provide a strong inner surface that resists the jamming of parts or material being conveyed.

There is a close tolerance fit between the apron shaft (axle) and the wings through which the shaft passes. The wings are installed on the shafts and can be separately replaced, if necessary. There are no welds to drill out or grind down to disassemble the wings. The retainer can be simply removed and the damaged wing replaced in a few minutes.

WIDE RANGE OF SIZES

Wardcraft's hinged steel belt has a 2-1/2" (64 mm) pitch and is available in any width from 3" (76 mm) to 60" (1524 mm) in 1" (25 mm) increments, at no extra charge, and in any length desired. Wardcraft's standard belt can replace Jorgensen and New London belts, and can be modified to replace Mayfran, Prab, Transcon and most other makes (total belt replacement is required).

Wardcraft also offers cleats with centers spaced in 2-1/2" (64 mm) increments, and sprockets with either a plain bore, or bored and keyed/bushed to your specifications.

CHOICE OF APRON SURFACES AND SIDE WING HEIGHTS

Plain, pimpled, or pimpled and perforated belt surfaces are available to suit your application. In addition, a divided belt with vertical lanes can be provided as desired.

Side wing heights (from apron surface to the top of the side wings) are 1-1/2" (38 mm) for the standard profile belt assembly, and 15/16" (24 mm) for the low profile model.

Wardcraft's low profile belt assembly is used where clearance is a problem; for example, in certain applications on cold heading and screw machines. The unit is available with 15/16" (24 mm) high cleats, and exposed side wing belt construction.

CONTINUOUS BELT WIDTH

An optional one-piece, full-width apron strengthens the belt assembly against center pressures and shock deflections. The continuous, uninterrupted surface also eliminates jamming of small parts that might occur on segmented belts. Maximum width for continuous surface is 36 inches.

STANDARD PROFILE

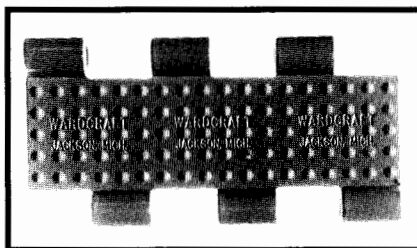
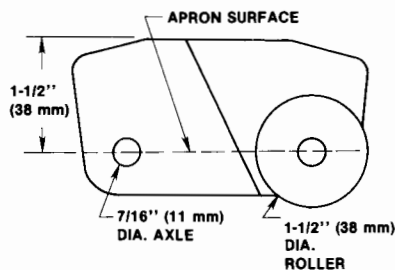

Pimpled surface belt for handling parts in oily condition, or with oily film.

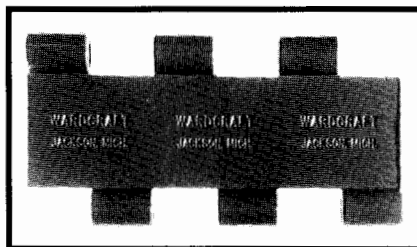

Plain surface for general parts handling applications.

LOW PROFILE

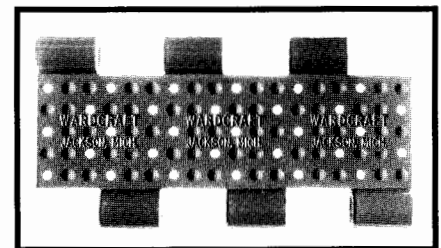
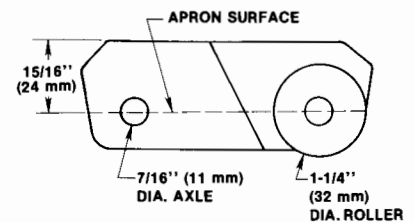

Pimpled and perforated surface for applications involving oily parts and chips where drainability is desirable.

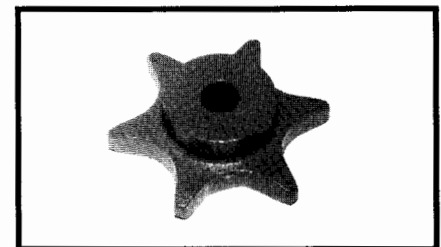

Heavy-duty cast iron sprockets are available.

WARDCRAFT

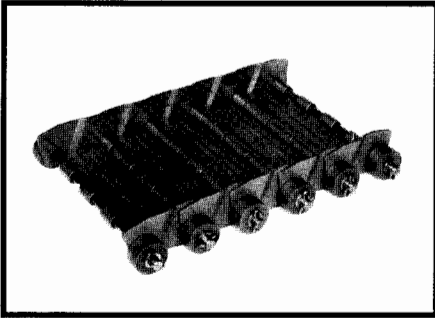

Hinged steel belt without side bars. Rollers are hardened steel 1-1/2" (38 mm) diameter x 3/4" (19 mm) side tapered to reduce drag resistance. (Note details of the interlocking side wing design.)

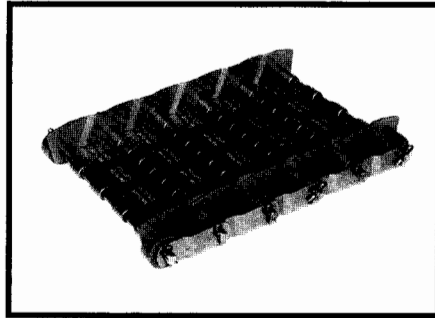

Belt with side bars has twice the chain pull rating of a belt without side bars. Double side bars are optional.

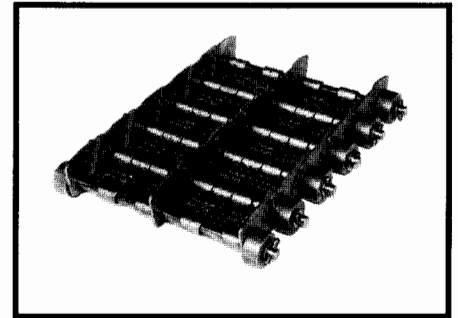

Divided belt provides separate lanes for segregation of parts or materials.

BELT DIMENSIONS

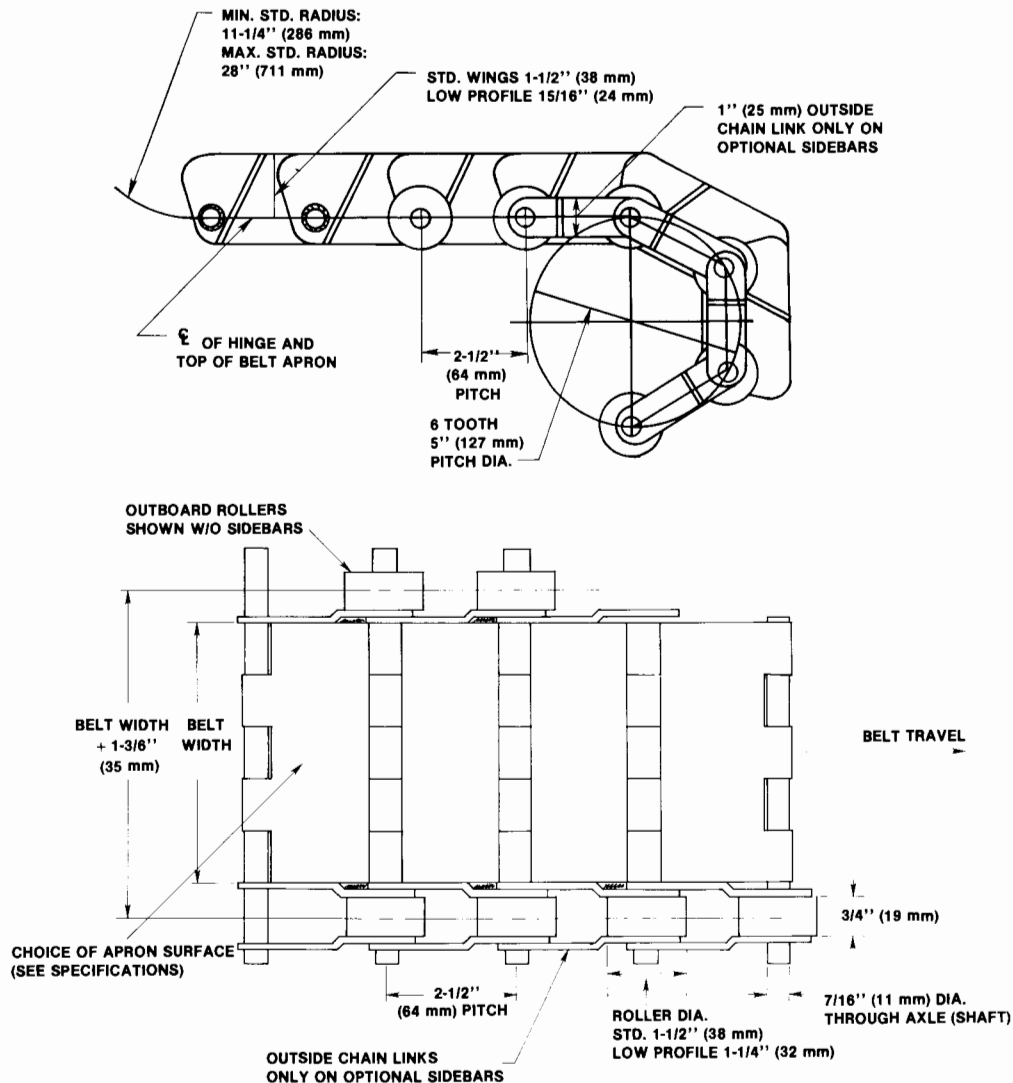

Wardcraft Hinged Steel Belts: for Longer Jam-Resistant Service

- Any belt width 3" to 60" in 1" increments
- Overlapping, interlocking side wings for extra strength
- Side wings pivoted on axles for easy replacement
- Continuous one-segment apron width available
- Plain, pimped, or pimped and perforated surface
- 2-1/2" pitch on axle centers
- Low profile belt assembly available
- Wardcraft offers a 2-1/2" pitch hinged steel belt to replace most other brands. 4" and 6" pitch replacement belts also available.
- Our delivery sets the industry standard

Wardcraft Hinged Steel Belt Specifications

Belt Widths*	3" (76 mm) to 60" (1524 mm) in 1" (25 mm) increments
Apron	12 gauge (.1046" - 2.7 mm)
Pimped Surface	3 pimples per linear inch
Pimped/Perforated Surface	2 pimples/1 perforation per linear inch. Hole size 1/8" (3.2 mm)
Plain Surface	Also available
Interlocking Side Wings	10 gauge (.1345" - 3.4 mm)
Shafts (Axles)	7/16" (11 mm) dia. high carbon steel
Sidebars	10 gauge high alloy steel
Sprockets (Std. Profile)	6 tooth 5" (127 mm) PD, cast iron
Sprockets (Low Profile)	5-tooth, 4.25" (108 mm) PD, cast iron
Rollers (Std. Profile)	1-1/2" (38 mm) dia. x 3/4" (19 mm) face, steel with ID and rolling surfaces heat-treated to 64 Rockwell .008" (.20 mm) deep. Larger diameter than competitors and side-tapered for additional life.
Rollers (Low Profile)	1-1/4" (32 mm) dia. x 3/4" (19 mm) face, and as above.
Cleats (Std. Profile)	1/4" (6.4 mm) flat stock, 1-1/2" (38 mm) high; cleat centers in 2-1/2" (64 mm) increments. Perforated, notched or tapered cleats optional.
Cleats (Low Profile)	Same as above except 15/16" (24 mm) high.

Specifications Subject to Change Without Notice **MADE IN THE U.S.A.**

* Belt width on Wardcraft steel hinge belts is measured between the side wings, as shown on the inside pages, unlike some other manufacturers whose belt width includes side wings. Accurate measurement of the width of the belt, both between and to the outside of side wings is critical to the manufacture of a correct replacement belt.



WARDCRAFT CONVEYORS

One Wardcraft Drive, Spring Arbor, Michigan 49283-9757

TEL: (517) 750-9100 • FAX: (517) 750-2244 • (800) 782-2779

Visit us www.wardcraftconveyor.com or www.quickdiechange.com